



THERMOCOUPLES CATALOG

2019

**MANUFACTURERS OF
INDUSTRIAL ELECTRICAL
HEATING ELEMENTS**

ABOUT OUR THERMOCOUPLES

USA MANUFACTURED QUALITY THERMOCOUPLES THAT NEVER DISAPPOINT

Rama Corporation offers a great selection of thermocouples to meet just about every need. We understand the importance of developing a reliable thermocouple to meet with customers high expectations. Thermocouples are used in a variety of applications and as safety measures as well. It is important to have a high standard quality thermocouple selection to produce the right one for each and every application. At Rama Corporation we offer just that. Take a look at our thermocouple selection. If you have any questions, just ask, our trained technicians are ready to help.

OUR TEAM



PEGGY RENSHAW
CEO



MICHAEL DAILEY
CAO



SHANNA ROGERS
CFO



MICHELLE POZOS
Engineering Manager

Established in 1947, Rama Corporation is a registered company in San Jacinto, CA. We have been in the business of developing and pioneering new electrical heating techniques for Over 70 years. We are continually evaluating and adding new product lines to stay aligned with our customers and market needs. We are also insured and bonded for our clients' protection.

Our clients come to us with their heating needs. We provide them with a cost effective solution. We are known for our innovative approach and that makes us the most trusted heating element manufacturer in the area. We have partnered with aerospace, medical, dental, commercial, plastics, aviation, military, nuclear, electronic, and automotive industries.

SHEATHED THERMOCOUPLE (TYPE TC1)

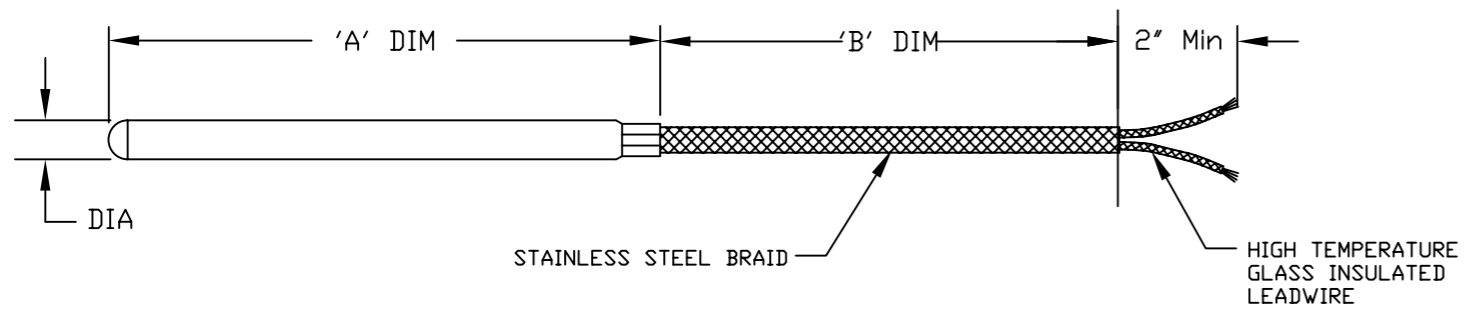

THERMOCOUPLE EXTENSION WIRE

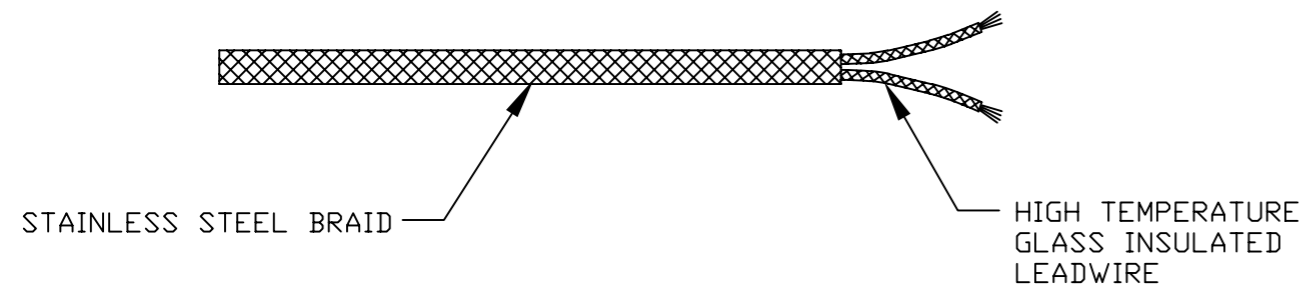

BAYONET FITTING ADAPTER

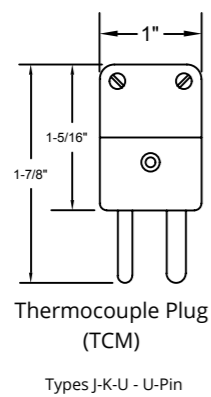

THERMOCOUPLE CONNECTORS

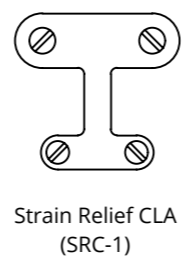
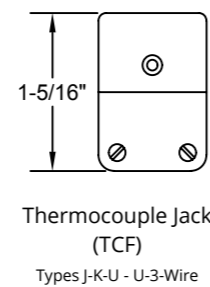

SHALLOW DEPTH THERMOCOUPLES (TYPE TC3)

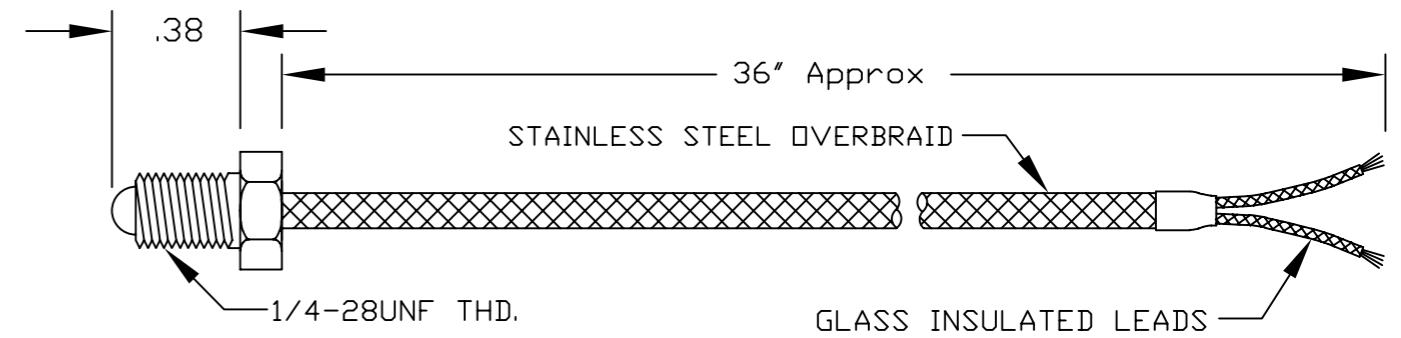

Note:
1. Operating temperature is 900°F Max

ADJUSTABLE DEPTH THERMOCOUPLE (TYPE TC5)

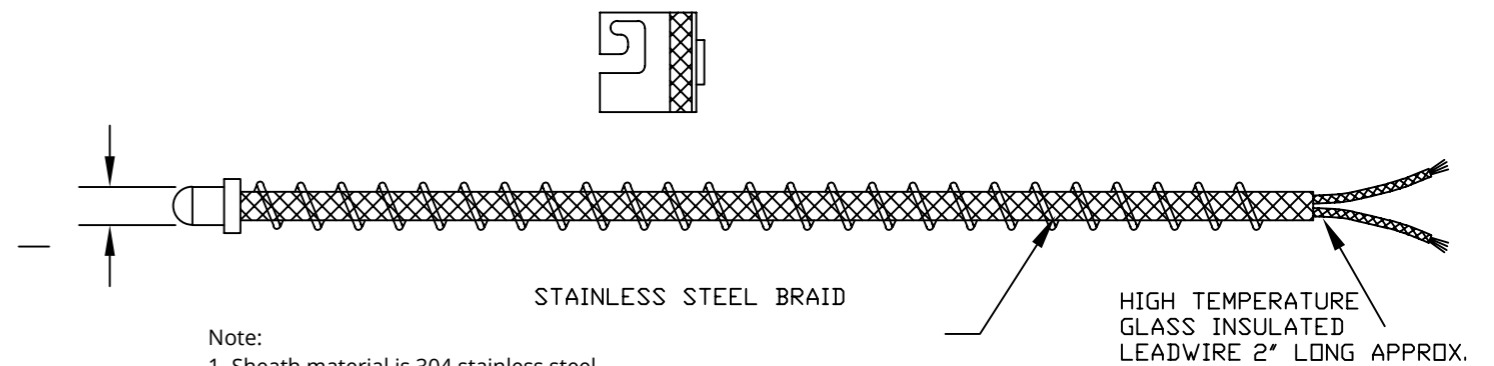

Note:
1. Sheath material is 304 stainless steel
2. Operating temperature is 800°F Max

**SURFACE WASHER THERMOCOUPLE
(TYPE TC6)**

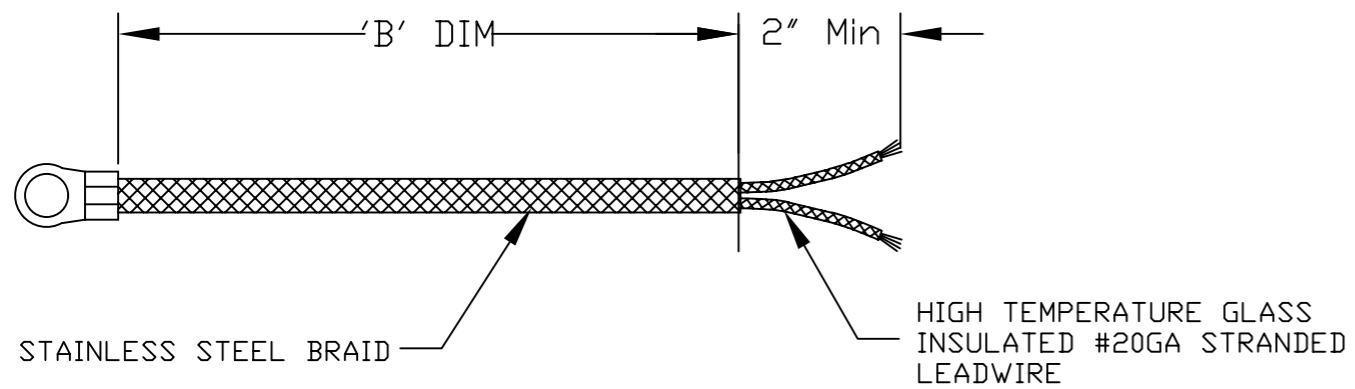

**INDUSTRIAL "STICK ON" THERMOCOUPLE
(TYPE TC7)**

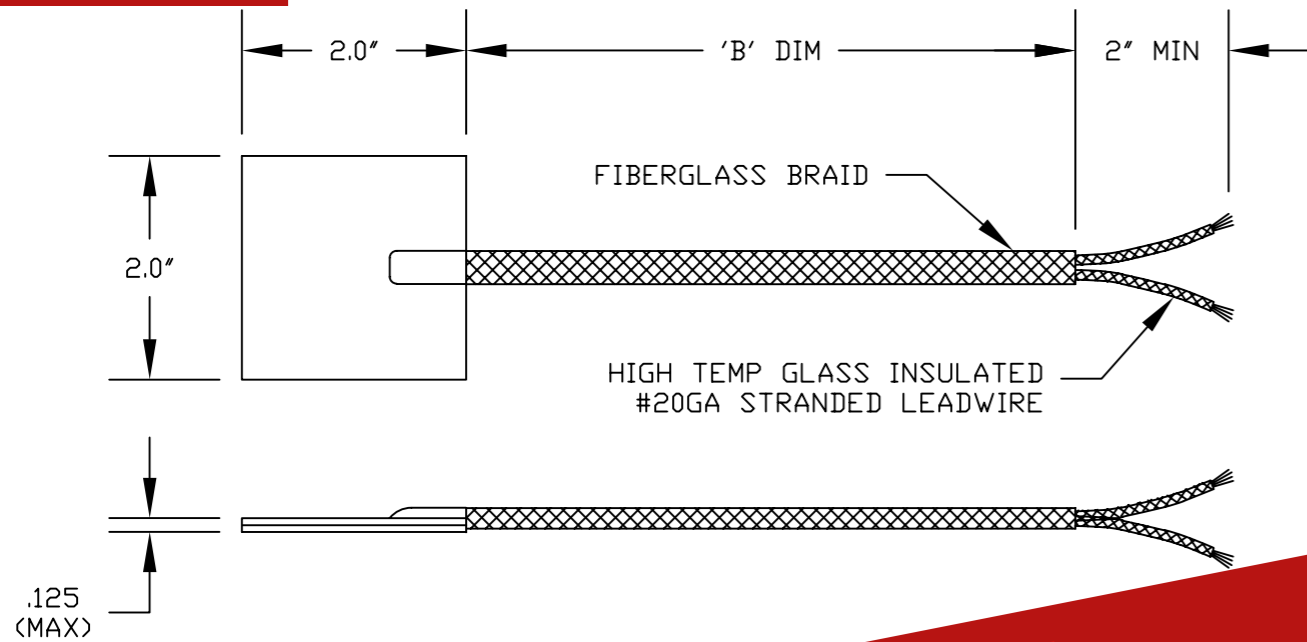

**THERMOCOUPLE FOR RAMA CAST BAND HEATERS
(TYPE TC8)**

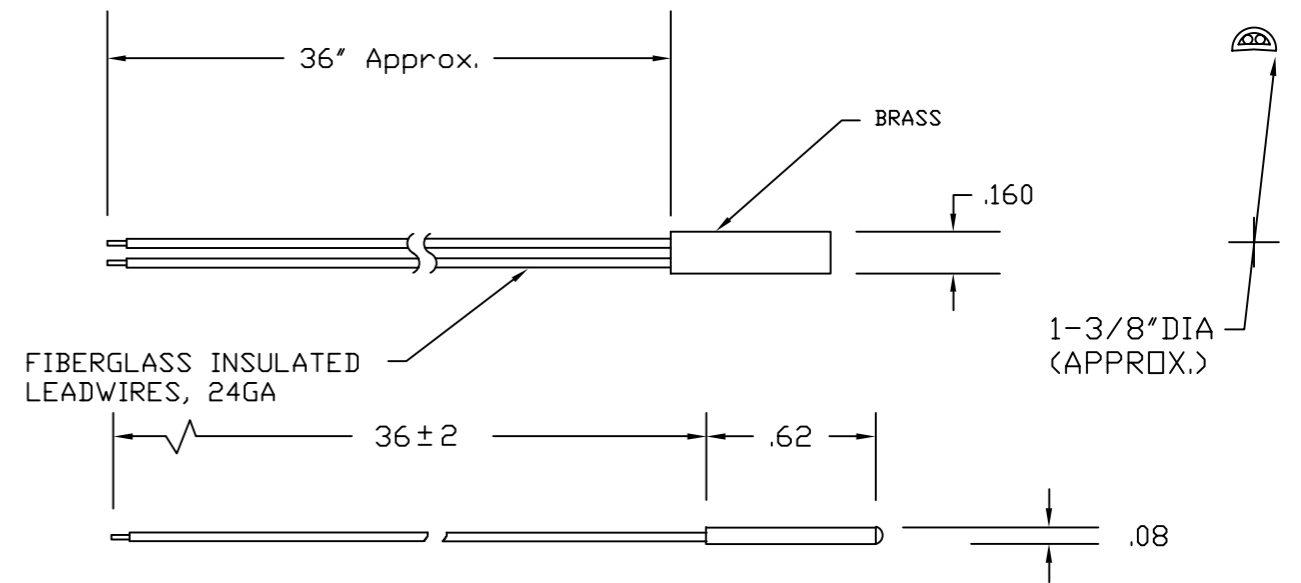

**CURVED SURFACE THERMOCOUPLE
(TYPE TC9)**

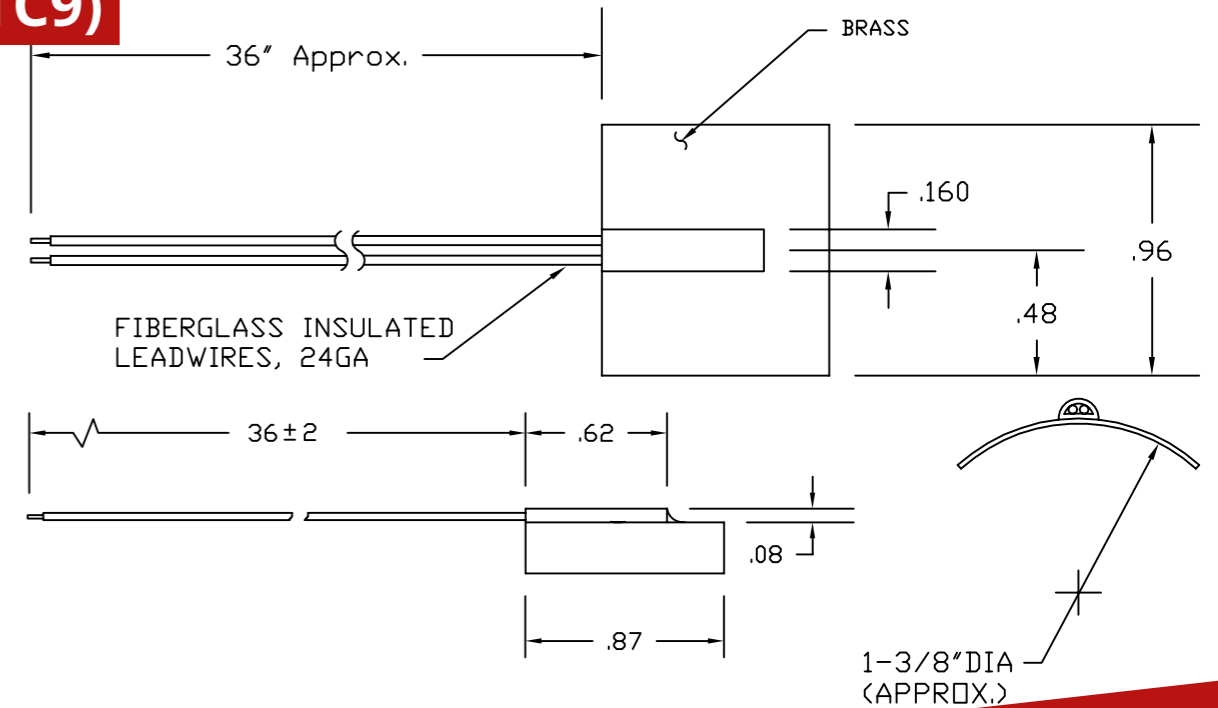



TELEPHONE

P: (800) 472-5670
F: (866) 255-4414

E-MAIL

sales@ramacorporation.com
ramacorporation.com

ADDRESS

600 West Esplande Ave
San Jacinto, CA 92583